

Bernard Enjolras
Research Director, Institute for social research.
E-mail: bernard.enjolras@socialresearch.no

And

Ragnhild Holmen Waldahl
Research Fellow, Institute for social research.
E-mail: ragnhild.holmen.waldahl@socialresearch.no

Institute for Social Research, Postbox 3233 Elisenberg, N-0208 Oslo, Norway

Phone: (+47) 23 08 61 24

Telefax: (+47) 23 08 61 01

Article for the 8th International conference of ISTR 9-12 July 2008 in Barcelona, Spain.

**Democratic governance and oligarchy in voluntary organizations:
the case of the Norwegian Olympic Committee and Confederation
of Sports**

Abstract

The main issue when considering the democratic governance of voluntary organizations is that the organization's claim to be a democratic body is not necessarily confirmed by the reality of the organization. According to Michels (1949) almost all voluntary organizations are characterized by the "iron law of oligarchy" i.e. the control of the organization by those on the top and the lessening of influence by members. Lipset *et al.* (1962), considers three factors leading to oligarchic governance of voluntary organizations. First, large-scale organizations give voluntary organizations officials a near monopoly of power. Second, the leaders want to stay in office since they may get prestige and material benefits from their positions. Third, the member may be passive. Although high participation is not necessarily a sign of democracy, the maintenance of effective opposition to leaders requires membership participation.

The paper addresses this issue empirically, by discussing the results of a qualitative study of the Norwegian Olympic Committee and Confederation of Sports. The empirical qualitative survey is based on a case study approach. We have surveyed, in addition to the umbrella organization, four sport federations: football, handball, athletics, and orientation; four regional federations and eight local clubs. The data comprehend observations of democratic processes (general assembly, board meetings), analysis of internal documents and about 50 interviews of leaders and board members at all levels.

The paper analyzes the empirical material along four dimensions of institutional democracy: representation, competition, participation and deliberation. The findings are discussed in order to cast light over the issues of oligarchy and power in voluntary organizations. The empirical findings are also discussed, more generally, in relation to the issue of the contribution of civil society to societal democracy.

1. Introduction

Voluntary organizations constitute an important component of the "democratic infrastructure" in democratic countries. They contribute to societal democracy by the play of individual skills effects (the school of democracy argument), public sphere effects and institutional effects (Warren, 2001). Among the potential institutional effects of voluntary organizations, a major avenue linking voluntary organizations and societal democracy is that of interest representation where voluntary organizations speak on behalf of their members.

In Norway, as it was the case for the other Scandinavian countries, the modernization of society from the mid-1800s is associated with the growth of numerous associations and voluntary organizations and their structuring into national movements and umbrella organizations (Klausen & Selle, 1996). These organizations were, from the outset, membership-based organization integrated into a hierarchical and nationwide organizational structure (an umbrella organization) with a democratic governance structure linking the local, regional and national levels of organization within which the local organizations had a great deal of influence. This hierarchical and democratic organizational structure - even if some trends toward a decoupling between the local and national level may be observed (Østerud, 2003)- still characterize the way the main subfields within the Norwegian voluntary sector

are organized, as it is the case with voluntary sport organizations which are under our focus in this article.

Norwegian voluntary sport organizations federated under the Norwegian Olympic Committee and Confederation of Sports (NOC) display consequently a formal governance structure based on two main principles. First, membership is associated with democratic rights. To be a member entails the possibility to express one's opinion, to participate in internal elections and to be a candidate to elected positions. Second, the local organizations elect representatives to the regional and national levels of the federation. Through this representative mechanism it is expected that the umbrella organization will express and represent the interests of the grassroots organizations. Conversely, this representative mechanism confers legitimacy to the umbrella organization, since it represents the local organizations, when acting in the public sphere or dealing with government.

In such a system, the umbrella organization's legitimacy and efficacy is contingent upon well functioning democratic governance. However, one of the main issues when considering the democratic governance of voluntary organizations is that the organization's claim to be a democratic body is not necessarily confirmed by the reality of the organization. According to Michels (1949) almost all voluntary organizations are characterized by the "iron law of oligarchy" i.e. the control of the organization by those on the top and the lessening of influence by members. Lipset *et al.* (1962), considers three factors leading to oligarchic governance of voluntary organizations. First, large-scale organizations give voluntary organizations officials a near monopoly of power. Second, the leaders want to stay in office since they may get prestige and material benefits from their positions. Third, the member may be passive. Although high participation is not necessarily a sign of democracy, the maintenance of effective opposition to leaders requires membership participation.

In this article we address this issue empirically, by discussing the results of a qualitative study of the Norwegian Olympic Committee and Confederation of Sports (NOC). We ask whether the internal governance of the organization functions according to its founding democratic principles and whether evidences of oligarchy characterize its internal governance. The empirical data for our analysis are based on a case study approach. We have surveyed, in addition to the umbrella organization, four sport federations: football (soccer), handball, athletics, and orientation; four regional federations and eight local clubs. The data comprehend observations of democratic processes (general assembly, board meetings), analysis of internal documents and about 50 interviews of leaders and board members at all levels.

The next section introduces the institutional context of our study and the organizational construction characterizing the Norwegian Olympic Committee and Confederation of Sports (NOC). Section three presents the data and the method adopted for this study. We adopt a "congruence analysis" strategy for collecting and analyzing our data which starting with a theoretical approach and assessing the capacity of the theory to explain the outcome of a given case. Democracy theory is characterized a plurality of normative and conceptual approaches and models. We retain and analyze the empirical material along four theoretical approaches of democracy: representation (section four), competition among interests (section five), participation (section six) and deliberation (section seven). The last section discusses the results and concludes.

2. Institutional background

Norway is a small country, with only 4.5 million inhabitants, located in the northern part of Europe. In comparison with other European countries, Norway has a less developed voluntary sector within the fields of welfare, social services and education. However, the voluntary sector within the fields of culture and sport are more developed in Norway than in most other European countries (Sivesind, et al., 2002). This fact indicates a specific repartition of roles between state and civil society in Norway. Whereas the state is mostly responsible for the provision of welfare, most sport and cultural activities are organized on a voluntary basis. In fact, only voluntary organizations can be members of the Norwegian Olympic Committee and Confederation of Sports. In comprising 29 percent of all organizations and 26 percent of all members of voluntary organizations, sport organizations form the largest sector within Norwegian voluntary organizations. In total, there are about 7000 sport organizations, based either on a single sport or multi-sport. All local sports clubs are federated at the regional level. Sport organizations are also federated at the national level according to sport discipline. There are 19 regional (or county) federations, and 56 national federations. Regional and national federations are represented under the umbrella organization, The Norwegian Olympic Committee and Confederation of Sports (NOC). This body enjoys a relatively high level of autonomy with regard to both the regulation of organized sport and the allocation of finance to sports organizations. While the regulations are determined internally and adopted by the NOC general assembly, financing is provided largely in the form of state grants which are administrated by NOC without government intervention and allocated to the sport federations.

The NOC, as it is the case for most social movements in Norway, is a membership-based organization with a representative democratic organizational structure, where the local organizations are linked to the national umbrella organization through a hierarchical integration process across the levels of governance. This process is reflected in a vertical construction including local, regional and national organizations. In addition to this multi-level structure, the NOC is characterized, as a result of its history, by a division between two lines as displayed by figure 1.

Figure 1: The organization of the NOC system in relation to the political/administrative system

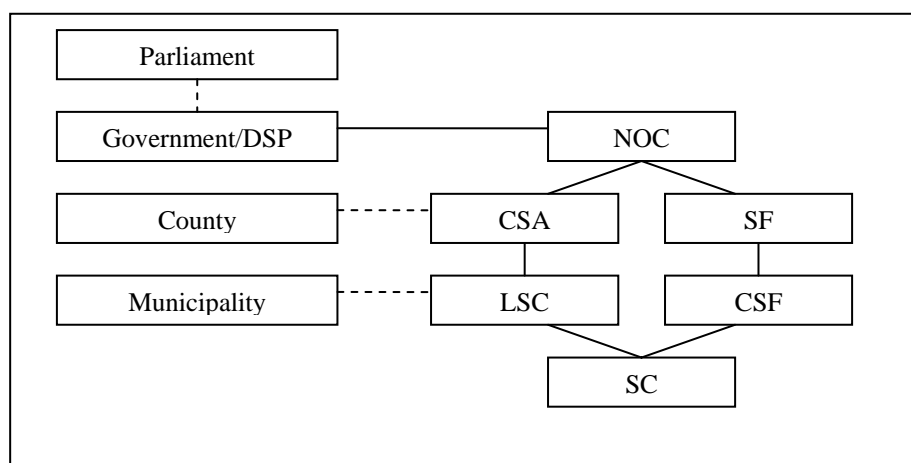

The NOC system comprises several types of organizations which are organized in two historically constituted lines. One line takes care of the common sports policy at various levels, and includes: *County Sport Associations* (CSA, n = 19), there is one for each county; and *Local Sport Councils* (LSC, n = 380), there is one in every municipality with more than three sports clubs.¹ The other, so-called special sport federation line, includes: *Sport Federations*² (SF, n = 56), in principle each SF governs one sport discipline³ nationally, and is member to an international federation; and *County Sport Federations* (CSF), these are regional organizations of SF, governing the sport discipline in every county with an appropriate number of sports clubs within that particular sport discipline. On top, the lines go together in the central NOC⁴ i.e. the umbrella organization, and in the bottom are the local *Sport Clubs* (SC, n = 7.500).⁵ Some sport clubs are specialized clubs organized around one sport discipline whereas others are multi-sport clubs offering several sport disciplines. The sport clubs are members of the two organizational lines i.e. they are member of one or several Sport Federation at the county and national level as well as member of the Local Sport Council and the County Sport Association.

Formally, the way each type of organization within the NOC is democratically governed is regulated by the NOC's internal law. The democratic governance of all NOC's organizational levels is based on some common principles and rules. The Annual General Meeting (AGM) is the higher authority of the organization and elects the members of the organization's board who are in charge of the management and leadership of the organization until the next AGM. The different types of organizations within the NOC system have the membership with voting rights participating to their AGM displayed by table 1.

Table 1: Membership with voting right according to the type of organization with the NOC

AGM	Membership with voting rights
<i>Voluntary Sport Club</i>	Members of the Sport Club
<i>Local Sport Councils</i>	Sport Clubs within the municipality
<i>County Sport Federations</i>	Sport Clubs within a given sport discipline localized in the county
<i>County Sport Associations</i>	County Sport federations and Local Sport Councils Direct Sport Clubs participation is possible
<i>Sport Federations</i>	Two models: 1) only Sport Clubs 2) Sport Clubs and County Sport Federation
<i>NOC as umbrella organization</i>	75 representatives from Sport Federations 75 representatives from County Sport Associations The members of the board in exercise

¹ Out of the 420 municipalities, there are sport councils in about 380 of them.

² In international literature, these are usually referred to as national sport federations.

³ Here are major variations. For example, the ski federation governs cross country skiing, other Nordic disciplines (ski jumping and biathlon) as well as alpine disciplines.

⁴ With the central NOC, we mean the umbrella organization constituted by its general assembly, board, and central (national) administration.

⁵ Including work place sports clubs there are 12.000.

The NOC, through its different levels and different types of organizations, constitute a representative system, where the local clubs are represented directly or indirectly (through other organizations they are members of) at the different levels of the system. One feature of this system which is important to stress is the fact that the AGM of the NOC as umbrella organization is composed of 75 representatives from the Sport Federation line and 75 representatives from the County Association line. This composition of the AGM ensures a balance of power and influence between the two organizational lines constituting the NOC.

In addition, the NOC's internal law defines the procedure to be followed for the holding of the AGM that aims at ensuring democratic rights. This procedure requires that a list of formal criteria and demands are met: validation of the rights of the participants/representatives, validation of the agenda, election of AGM leader and secretary, discussion and adoption of the yearly report and the yearly accounts, choice of an auditor, discussion and adoption of sport-policy-related issues, discussion and adoption of internal law issues, election of representative to the board and to specialized committees. The first set of criteria, validation of the rights of the participants/representatives and of the agenda, aims at guaranteeing that only those who are entitled participate in the AGM and that they have got the necessary information in order to exercise their democratic role. The second set of criteria, election of AGM leader and secretary, aims at guaranteeing that the democratic procedures, especially deliberation and voting, are fair and made public. The third set of criteria, discussion and adoption of the yearly report and the yearly accounts and choice of an auditor, is related to the accountability of the board beyond the AGM. The fourth set of criteria, discussion and adoption of sport-policy-related issues, discussion and adoption of internal law issues reflects the AGM's political and legislative role, whereas the last set of criteria, election of representative to the board and to specialized committees, is the expression of the AGM's sovereignty.

3. Data and method

Our analysis of NOCs democratic governance is based on a qualitative survey carried on in the spirit of the case-study research tradition. The aim of such a qualitative empirical approach is to elaborate a complex holistic representation of a social phenomenon, here the democratic governance of a complex voluntary organization, by interpreting and giving a systematic meaning to a collection of different type data (interviews, observations, documents). Our methodological orientation in the analysis of the data is best characterized as a "congruence analysis" perspective. Congruence analysis takes its point of departure in a theoretical approach and tries to assess the capacity of the theory to explain or predict the outcome of a given case (George & Bennett, 2005). One makes the assumption that there is a relation between the variance in the independent variable (the case) and the variance in the generalization (the theory). The researcher starts with the values of the independent variables and predicts with the help of the theory what happens with the dependent variable. If the outcome is consistent with the theoretical prediction it is possible to consider that there exists a causal relation (George & Bennett, 2005:181). This type of approach entails that the researcher seeks identifying empirical regularities that fits the theory but also risky implications i.e. surprising and uncommon empirical implications to be expected if the theory is to be supported (Andersen, 2007).

Case-study research focuses on a limited number of entities. In organization research this implies studying different aspects of a complex field by analysis a little number of

organizations. A challenge linked to case-study research in organization where few organizations are under study, is the possibility to generalize the findings to the field or to the population of organizations. Our data are not representative of Norwegian voluntary sport organizations part of the NOC. However, this does not mean that a degree of generality in our conclusions is not attainable. First, we used a purposive sampling method in order to get maximal variation in the selected cases concerning the localization of the organization, the sport discipline and the type of organization. Second, we carried a congruence analysis of the data anchored in different theories. That implies that the particular and local findings are related to more general (and theory-grounded) implications and causal chains of reasoning. Third, since the analysis focuses on regularities concerning the processes characterizing the internal governance of voluntary sport organizations, we can consider that, given the fact that the same causes produce the same effects, it is likely that the organizations that share the same environmental conditions will be more or less characterized by the same internal processes. When internal processes differ we should be able to identify idiosyncratic organizational features explaining the variations.

The choice of cases was dictated by the necessity to study the different levels and the different types of organizations constituting the NOC: local Sport Clubs, County Sport Associations, County Sport Federations, Sport Federations, and the central NOC i.e. the umbrella organization. The main reason for focusing on these organizations and levels (and excluding the Local Sport Councils) has been to be able to trace how members' interests and opinions, at the local level, are taken into account through the different levels within NOC's representative system. Another guiding criterion for the choice of cases was to maximize variation with regard to observable features like size, localization and activity profile. Four Sport Federations, representing different sport disciplines, football (soccer), handball, athletics, and orientation, have been chosen. Football and handball are popular and dynamic sports in Norway and the two federations are among the biggest one. Orientation is a traditional Scandinavian and somehow elitist sport in Norway, whereas athletics is a traditional discipline but relatively small in Norway. Four County Sport Associations were chosen in order to give geographical variation across the Norwegian territory. Within these counties we have studied, in addition to the County Sport Associations, local Sport Clubs and County Sport Federations within the four disciplines: football, handball, athletics, and orientation.

Our data include participant observations, interviews and documents collected in 2006 and 2007. Participant observations were made by being present in nine local Sport Clubs' AGM, observing one County Sport Associations' AGM, participating in two Sport Federations' AGM, and two of the central NOC's AGM. In addition, we have interviewed 50 leaders and members of the board of the organizations studied. For each organization we have collected annual reports, action plans and policy-documents, minutes of the board meetings, and AGM documents. Participant observations provided us with information regarding how the formal democratic procedures are implemented, who participated, which topics were debated, which issues were conflict-laden and which interests and arguments were defended and made by different interest-groups within the organizations. The interviews with leaders and board members gave us a better understanding of how decisions are made, which political conflicts are relevant for the organization and how they are solved, how the elections are made, which power relations and conflict of interests characterize the relationship between the different type of organizations composing the NOC, what is the role of the leader and of the board, etc. The limitation of this type of interview is obviously that it reflects the meaning and experience of an "elite" and not that of the basic member. However, during our participant observations we had informal conversation with basic members that helped us to form our

understanding of how the internal democratic governance functions. Finally, the analysis of documents provided us with considerable information on organizations' activities, decisions, democratic procedures, debates and relationships between the board and the members and with the organization's environment.

Theories of democracy are manifold and the concept of democracy is a contested concept opening for different "models of democracy" (Held, 1987). In spite of a multiplicity of models, one can distinguish three normative conceptions (Allern & Pedersen, 2007): competitive democracy, participative democracy and deliberative democracy. Competitive democracy emphasizes the role of voting as a mechanism making possible the aggregation of political preferences, the choice among interests in competition, and the selection and the accountability of the leaders. Participative democracy focuses on the active participation of all citizens in political activities and decision-making processes. Deliberative democracy underscores the possibility to solve conflicts of interest through rational discussion and deliberation in the public space. Instead of entailing preference aggregation (as it is the case with voting) deliberation leads to preference transformation. In addition to these three normative conceptions, one can make a distinction between direct democracy and representative democracy. If, on a theoretical plan, one can distinguish different normative conceptions of democracy, in practice, political institutions (as it is the case with the NOC) incorporate at varying degree some characteristics of these different conceptions. We analyze the empirical material along these four dimensions of institutional democracy: representation, competition, participation and deliberation.

4. Representation

The NOC as already stated is an organization composed of different types of organizations at different levels of governance. The complexity of the organization entails that its democratic governance is based on the principles of representative democracy: formal rights, majority decision-making rule, and representation. These principles are implemented through the organizations' AGM where the members (individuals or organizations' representatives) elect according to the majority rule the board and the leader of the board. The board of the organization is accountable before the AGM. Representative democracy implies that at each governance levels the elected representatives and the elected members of the board are representative for their constituencies. This simple principle is however more complex than it appears at the first sight since the notion of representation is a complex one that takes several meanings in democracy theory. How representative of their constituencies are the elected representatives is contingent upon which understanding of the notion of representation one privileges.

Pikin (1967) differentiates two main understandings of the notion of representation: a formalist and a substantial understanding. The *formalist conception* focuses on the relationship between constituencies and representatives and may take two forms, either (i) the authoritative form where the representative is conferred by the group authority and legitimacy, for acting on behalf of the group; or (ii) the accountability form where the representative has to answer before the group for what he does. In the authoritative conception, the legitimacy of the representative springs from the mandate which has been conferred by the constituencies to

the representative. In the accountability conception, the representative's legitimacy is due to the representative's obligation to account for (before the constituencies) what has been done by the representative. In democratic representative systems it is usually the accountability-based conception which is in vigor. The *substantive conception* is concerned with the content, the ways representatives represent their constituencies. This substantive conception may also take two forms: either (i) as "standing for" i.e. being something for the group, (the representative can stand for the group because he is (a) mirroring, reflecting the composition of the group or (b) "standing for" symbolically i.e. expressing the identity of the group) or (ii) as "acting for" the group, the action of the representative has to be judged, in this case, accordingly to what he does and how he does it (how he performs his role). It is also possible to distinguish two conceptions of the substance of acting for according to the nature of the interests which are represented: unattached interests (general interest) or particular interests. "Acting for" may as well take two modalities according to the nature of the mandate that links representatives and constituencies: imperative mandate vs. independence of the representative. The representative system of the NOC is based on the accountability-based conception of representation. Representatives are supposed to "act for" their constituencies; they are not bounded by imperative mandates. It is however unclear whether they are supposed to represent the general interest (of the sport organization) or to represent particular interests.

Another issue related to the notion of representation is its ambiguity when it comes to the relationship between the "elites" or "sub-elites" (Etzioni-Halevy, 1993) and "the people". According to Manin (1997) representative democracy is a mix of democratic principles (government by the people) and aristocratic principles (government by elite). Historically, representative democracy was instituted in full awareness that elected representatives would and should be distinguished citizens, socially different from those who elected them (Manin, 1997: 94). From this viewpoint, elections are inherently aristocratic, by their very nature they cannot result in the selection of representatives who resemble their constituents. These theoretical considerations led us to focus on two main questions related to the functioning of representative democracy within the NOC. First, to which extent the mechanisms of representative democracy functions across the multi-levels of organizational governance in order to insure accountability of the representatives and leaders and their renewal in order to avoid oligarchic tendencies? Second, to which extent the representatives and leaders are alike or different, in terms of social characteristics, experience and qualification, from their constituencies?

Both accountability of the representatives and their renewal take place within the framework of the organizations' annual AGM. At the local sport clubs level, in all AGM we participated, the formal procedures were respected. In most of the cases that were few members who were present and participated in the AGM. Those who were present were engaged members or those who had formal functions and responsibilities within the organization (members of the board, members of committees). In several occasions the AGM had difficulties to find candidates to the available board and committees available functions, in spite of the existence of a so call "election committee" which, previously to the AGM, is in charge of contacting and proposing potential candidates. The combination of low participation and of difficulties in getting candidatures may indicate a lack of interest and engagement of the members for the democratic life of their organization. During the AGM the present participants were not very actives: few questions and issues were raised, few debates were engaged. Even if the formal democratic rules were respected, the local clubs seem to suffer from a democratic deficit and a lack of engagement from their members.

At the county sport associations and the sport federations levels, similarly to what happened at the local level the AGMs were proceed according to the formal procedures. However, the democratic functioning of these organizations was not optimal since here also the participation rate (of the representatives from the local sport clubs) was low, even if participation was significant. As an example, 234 representatives from local sport clubs attended the AGM of the football federation in 2006 whereas the total number of clubs members of the federation is about 1800. Low participation rates at local, county and federation levels have negative consequences for the organizational democracy. First, both the AGMs' and the elected representatives' legitimacy is weakened. The extent to which the decisions which are made are anchored in the constituencies of the organizations may be put into question. Second, the representativity of the representatives is also weakened; it is unclear which interests and which constituencies the elected representatives represent. In addition, a selection process is probably characterizing the patterns of participation; the most motivated or the richest clubs may be more active than the mass of passive clubs. There is no guarantee that the participants share the same interests and opinions than the non-participants. These problems are becoming worse the higher the representation process is implemented in the organizational pyramid. Indeed, some representatives are indirectly elected and in some cases there are three degree of separation between the representative and its constituencies. That means that these representatives (at the sport federation level) are elected by representatives from county federations who were elected in AGMs with low participation from representatives elected by local clubs' AGM with low representation. Since each level of governance suffers from low participation, it is the all chain of representation which is weakened. This impedes also the representation at the AGM of the umbrella organization (the central NOC).

At the umbrella organization level, the functioning and dynamics of the AGM are mainly determined by the rules defining the composition of the AGM. As already stated, the AGM is constituted by representatives of two colleges: 75 representatives from the County Sport Associations and by 75 representatives from the Sport Federations. The basis for determining the number of representatives for each organization in each college is not their number of members but their number of local sport clubs. That entails that the organizations that have a lot of small clubs may have more influence that the organizations that have comparatively fewer big clubs. In addition, this system privileges the small federations/associations at the cost of the big ones. For example the five biggest organizations (football, workplace sport, skiing, handball and golf) representing half of the total of members in sport organizations had only 15 representatives to the AGM. The biggest organizations, as a consequence of the representative system, have relatively little influence on the AGM of the NOC. Another consequence of the rules of representation characterizing the AGM of the NOC is the existence of a power balance between the two organizational colleges that hinders a dynamic development of the organization and its democratic functioning. This "constitutional" power balance is almost impossible to change since a change in the internal law of the organization would require a 2/3 majority of the AGM, and none of the two colleges is willing to loose some influence and power to the advantage of the other. The AGM of the NOC has not, contrarily to the AGMs of the other organizations constitutive of the NOC, a participation problem, but a representation problem that endangers the democratic functioning of the NOC.

The leaders and members of the boards of the different organizations and levels of governance of the NOC differentiate themselves from the mass of the members by being more engaged and dedicated to sport and to their organizations, and by displaying character traits, qualification and ambition above the average. The top leaders have usually a long carrier with

different leading positions within sport organizations before they get a position at the national level. They are consequently not representative (statistically) of the mass of members, but have a long experience and deep knowledge of sport organizations at different levels. In a nutshell, top leaders are part of an elite or sub-elite within sport organizations.

The combination of low participation rates at the different level of the NOC and of elite leadership may lead to the development of an oligarchic system. However, we did not find evidences of such a tendency within the NOC by looking at its representative system, since the turnover of the leader was significant. One explanation to this may be the role played by the “election committees” at the different levels of the organization in contributing to renewing the candidates to positions. Each AGM elects an “election committee”, usually composed of veterans and former leaders of the organization that have a large contact net within the organization, with the mission of proposing candidates to board, committees and leading positions at the next AGM. These “election committees” play an important role in organizational democracy because they select potential candidates to positions. The AGM has the possibility to challenge the proposal of the committee by putting forward alternative candidatures, but usually the proposal of the committee is approved by the AGM. In addition to proposing candidatures, the “election committees” have an important dogwatch function because they have the ability to not renew the candidatures of representatives who did a bad job or misused their positions. They also contribute to the renewal of positions by searching for new potential qualified candidates. Another explanatory factor, is the existence of a “democratic culture” within the NOC among members, representatives and leaders, that hinder the development of an oligarchy, that entails that the leaders and representatives that do not behave accordingly to democratic principles will be exposed to social pressures within the organization and will not be in capacity to monopolize organizational resources to the perpetuation of their positions.

5. Participation

As already stated, the lack of active participation and engagement on behalf of the members may be a source of oligarchy. According to Michels (1949), by controlling resources (knowledge, means of communication, skills in the art of politics), the leaders have an advantage over members who have neither time and nor resources allowing them to compete for power with the leaders. In the previous section, we have already established that, even if we were not able to find out trace of oligarchy, the members’ lack of effective participation (absenteeism) the outcomes of democratic processes may lose its legitimacy. In this section, we shall focus on the reasons and factors that explain the relatively low participation of the members.

According to democracy theories, the deficit of participation may be related to two main sources (Dahl 1982; Gutmann & Thompson, 1996; Habermas, 1996; Young, 1999):

- The members’ lack of “enlightened understanding.” Enlightened understanding is often put forward as a condition for active participation and supposes that each citizen (here member) has an equal opportunity of access to resources in order to make its judgment on a decisional topic. The unequal distribution among members of political skill and cultural resources may lead to the domination of democratic processes by a minority and threaten those who feel not qualified to participate. The well-functioning of deliberative processes presupposes the equality of each participant within the communicative process leading to mutual understanding, what Gutmann & Thompson (1996:17) maintain when stating: “deliberation does not have priority over liberty and

opportunity.” This problem is also recognized by Habermas (1996, p. 324) when he remarks that “reaching mutual understanding through discourses indeed guarantees that issues, reasons, and information are handled reasonably, but such understanding still depends on contexts characterized by capacity for learning, both at the cultural and the personal level.” Due to the complexity of the matters to be dealt with and to the unequal opportunity of access to resources, deliberation within the organization may also lead to power appropriation by specialists and to member passivity.

- The members’ lack of control over the final agenda. The lack of members’ participation and the absence of enlightened understanding may give the elite a control over the agenda and therefore allow them to define the terms of the democratic decision process. Members may feel that they have no influence over the decision-making process and may for this reason prefer not to participate.

Our informants put forward several reasons for the lack of participation of the members. First, the low participation rate in AGMs is explained as the result of a lack of members’ engagement for the political processes. One main reason which is often referred to by our informants for this lack of engagement is the perceived lack of influence on decision-making. The lack of engagement is not necessarily perceived as resulting from indifference or lack of interest for these matters, but more as the result of a diffuse feeling that it does not make a difference. This phenomenon is even more accentuated at the County Sport association and Sport Federation levels where the representatives from the sport clubs have in isolation no influence. In order to make alliances and get influences a long organizational and political experience is needed. Second, another frequently invoked reason is the fact that most members are often involved in the daily running of the organization as volunteers and practitioners i.e. in driving and participating in sport activities, and are not so much interested in more organizational or political issues. Third, some informants point that engagement among members is unequally distributed, some members are burning for sport and sport organizations and are involved both in sport activities and in administrative and political activities at several levels, whereas others are not so engaged and more oriented toward their self-interest and self-development than taking responsibilities for the sport community. Fourth, economic reasons may also explain the lack of participation. Active participation, especially for those who take responsibilities as volunteers at the different levels of the NOC takes time and costs money. In the absence of monetary compensation, only individuals having the necessary resources in time and money are able to take leading positions. Finally, active participation demands both skills and self-confidence. In order to intervene in discussions and deliberation as well as to be elected as representative, individuals need to have specific knowledge on organizational and sport issues. They also need to have the necessary skills and self-confidence for speaking in public, making an argument, and for being part of a debate.

Participation in democratic processes within the different organizational levels of the NOC is relatively low. The main explanation for this lack of participation is that members are primarily engaged in sport activities. It takes time and resources in order to practice sport and to do voluntary work at the club level. Only those who are specifically interested in organization life and have skills and resources to do so, involve themselves in the political life of the organization at the local level. A few develop interest in sport politics and are engaged in the higher levels of the NOC. One reason for that is that the issues become more abstract and distanced from grassroots preoccupations at the higher levels of the organizational pyramid. In addition, participation in democratic processes requires not only motivation and interest but also political and organizational skills as well as resources in terms of time and

money. Consequently, there are many interacting factors contributing to the relatively low level of members' participation in democratic forums within the NOC.

6. Competing interests

Theoretical approaches of democracy can be placed into two groups (Mandbridge, 1992; Bohman & Rehg, 1997; Cunningham, 2002). On the one hand, one finds theories of democracy that consider democracy as a decision-making process aiming at finding a solution in presence of contradictory interests. This type of approach may be labeled competitive democracy, since it focuses on contradictory and competing interest. On the other hand, one finds theories that consider democracy as a decision-making process aiming at reaching a common good or common interest and emphasize deliberation as a means of attaining this goal. These two theoretical approaches are not necessarily excluding each other since most democratic institutions would be characterized by a combination of both processes. In this section we focus on the first approach to democracy, the competitive approach, whereas in the next section we will deal with the second one, the deliberative approach.

Common to the competitive approach to democracy are the idea of competition between egoist interests and the centrality of election as means for aggregating individual interests. Citizens or in our case members are seen as having fixed preferences, the political system being an arena for power struggle between contradictory interests. However, the different theories developed within this common approach, emphasize different aspects. Elite theory (Shumpeter, 1947) understands democracy as a competitive process aiming at selecting the best candidates to government among a set of competing candidates. Economic theory of democracy (Downs, 1957) sees citizens as utility maximizers who through election choose among competing candidates the candidate the closer to their interests and preferences. From this viewpoint, election and vote procedures are conceived as an aggregative mechanism of individual preferences. However, the aggregation of preference through vote may lead to irrational results as shown by Arrow's (1951) "impossibility theorem" and may fail to produce a conception of the common good (Ricker, 1982). The pluralist theory of democracy (Dahl, 1956) adds the idea that competition among organized interests and not only individual interests is characterizing the political system.

From the perspective of competitive democracy, the main issue to be analyzed concerns the nature of conflicting interests within the NOC, the ways they are organized and influence elections of representatives at the different levels of the organization. Here we focus on the structure of interest characterizing the different levels of the NOC and the extent to which they are part of the voting processes at the AGMs.

At the club level, the most important conflicts of interests are between mass and top sport and between different target groups like children, youngsters and seniors. In multi-sport clubs there exists conflicts of interests between the different sport disciplines. These types of interests' conflicts are usually solved through discussion between the stakeholders and the leadership of the club seeks to reach a consensus for the decisions which are made. At the County Sport Association level and at the Sport Federation level one finds the same types of conflicts of interests as it is the case at the local level, but other divisions characterize also the organizational levels. There is a structural conflict between the two organizational lines- Sport federation and County Sport Association- that is played out also at the County level. In addition, there exist polarized interests between the specific interests of each sport discipline

as opposed to the general interest of sport, as well as particular interests linked to gender, geography, and top vs. mass sport.

The conflicts between the two organizational lines are polarized around the repartition of competencies and functions (which organization line do what?), the issue of the adequate degree of centralization (which functions have to be at the national level and which functions have to be at the regional level?), and to the appropriation of monetary resources that in turn give the organization and its stakeholder power, influence and legitimacy. Each sport discipline has not necessarily congruent interests and different more or less loose coalitions exist among Sport Federation. One line of division among federation is due to their size. There are big differences between the big Sport Federations (more than 100 000 members) and the small ones (less than 10 000 members). In addition, there exist commonalities between Sport Federations due to the type of sport discipline they organize, for example among summer sports vs. winter sports, Olympic sports vs. non Olympic sports, individual sports vs. team sports, etc. These different coalitions have different interests when it comes to top-sport, economy and funding sources, facilities, and their expectations toward the umbrella organization.

An important interest-line is linked to the gender issue. Women are under-represented in sport organizations both as members and in governance positions. Women, as it is the case for example within the Football (soccer) Federation, constitute an interest group with a clear political agenda which is very active at all levels of the organization. Another line of division is related to geographical localization. Urban and populated County Associations have different interest than rural and less populated ones, especially when it comes to the repartition of public funding. The geographical localization plays an important role when choosing candidates to boards positions within the Sport Federations, to the extent to which it is customary that the regional balance has to be respected. The last dimension of conflict of interests is that of mass vs. elite sport. This dimension affects particularly the priorities of the organization and the allocation of financial means within the organization. This is especially the case within sports, like Football (soccer) where the top-clubs generate significant media and sponsor incomes and where a part of these incomes are allocated to mass sport. It is also the case within small federations where the members contribute to funding the elite team.

Those conflicts of interests are epitomized at the level of the umbrella organization and come to play at the AGM of the central NOK. During the last AGM (in 2007) not least than 4 candidates to the presidency position were declared some months before the election. Some of them were lanced by some coalition within the NOC. The big Federations had two candidates, the rural Counties one candidate, and the election committee has proposed a candidate. The final election was a clear competition between the candidate supported by the big Federations and that proposed by the election committee who eventually won the election.

Democratic politics and politics within voluntary organizations is not an exception consists in, given a plurality of particular interests, finding, if not a common interest, a platform which is supported by a majority and which benefit the community. The NOC is characterized by a plurality of more or less organized interest at all organizational levels seeking to maximize resources, positions, influence and power. A way to deal with those particular interests consists in, aggregating them trough voting procedures as it is the case in AGMs, and another way consists in reaching consensus through deliberation.

7. Deliberation

The theoretical understanding of democracy as competition was challenged at the beginning of the 80s by scholars that emphasized the importance of deliberation. The hypothesis according to which politics has to be understood as competition and conflict among interests has been questioned and a renewed interest in deliberation awaked after the publication of Habermas' (1984) "Theory of communicative action". Elster (1998) differentiates three methods that individuals use in order to make decisions in presence of conflicting interests: argumentation, bargaining and voting. Usually, the three methods are used by political institutions. Individual preferences may be submit to three operations through these methods: aggregation, transformation and misrepresentation. Deliberation and argumentation aims at, contrarily to voting which leads to preference aggregation, preference transformation. Deliberation, i.e. discussions about an issue involving different viewpoints that have the possibility to be expressed, that can lead to the elaboration of a consensus by the play of preference transformation or to the clarification of the alternatives that can be submit to vote, constitute an important momentum in democratic processes, as it is the case too in organizational democracy.

From the perspective of deliberative theories of democracy, the main issue to be surveyed is the extent to which the NOC democratic system of governance constitutes an arena for the deliberation of issues leading to political decisions internal to the organization. We focus here on where, within the organization, deliberations take place and how the agenda for deliberation is set up.

Deliberations within the organizations composing the NOC take place mostly within the board rooms and at the AGMs. At the local club level most of the decisions are preceded by some kind of deliberation both within the board and outside. When the representatives or the stakeholders disagree the leader usually seeks to come to a consensus by continuing the discussion until an agreement is obtained. During the AGMs at the club level few debates are engaged. However, our informants point that a lot of debate are going on informally among members and between the members and the board representatives at the occasion of voluntary activities. In addition to face-to-face contacts, new information and communication technologies (ICT) like the Internet, emails, SMS and mobile telephones facilitate communication and exchange of meaning between the board representatives and the members. This kind of network-based deliberation seems to develop as a compensation for the relative low level of participation within formal democratic arenas.

At the other levels of the NOC (County Sport Association, Sport Federations, and umbrella organization) the decision-making process is largely conditioned by the formal structure – board, professional administrative staff, specialized and consultative committees, AGMs – that characterizes the organizations. Often, decisions are discussed and elaborated in committees where the different stakeholders of the organization are represented with the support of the professional staff before they are discussed and adopted by the board. This decision-making structure gives the professional staff a decisive influence on decisions, even if in some cases the board may take initiatives.

The issues on the agenda are discussed by the board representatives before the decision is made. During this process the different interests and arguments are expressed and thoroughly debated. Usually boards' decisions are made on a consensus basis, and when a consensus is not reached the disagreement is reported on the minute of the meeting and the decision made

by means of voting. The AGMs of the different components of the NOC constitute also arenas for deliberation, even if some weaknesses characterize those deliberations. Due to the number of issues that have to be discussed and voted during a short period of time, many of the proposals are adopted without a real debate or after some comments from representatives that have more a rhetorical function aiming at personal promotion than a real input to the discussion.

Deliberations take place within the NOC, but the nature of the issue and themes that are debated is heavily determined by the formal structure of both the organization and the decision-making process. The multi-level structure of the organization contributes to filter the issues that reach the higher levels of the organization and these issues are often more determined by the strategic goals and preoccupations of the given organization than by the preoccupations of its constituencies. The structure of the decision-making process – preparation by committees with staff input and influence, discussion and adoption by the board, validation by the AGM- contributes too to the filtering of the issues to be debated and the interests and arguments to be expressed. These filtering processes can produce a form of decoupling between the grass-roots constituency and the top of the federal pyramid.

8. Discussion and conclusion

In this concluding section we discuss on the basis of our empirical results the extent to which the internal governance of the NOC functions according to its founding democratic principles (membership is associated with democratic rights, representation of the constituencies at all levels of the organization, and representation of grass-roots interests by the umbrella organization) and the extent to which evidences of oligarchy characterize its internal governance.

Participatory democracy within the NOC is weak both when it comes to members active participation in clubs' AGMs and to clubs participation in County Sport Associations and Sport Federations' AGMs. In addition the recruitment of candidates to governing position is difficult especially at the local level. These combined factors contribute to weaken the functioning of representative democracy within the NOC. Low degrees of participation at the local level undermine the legitimacy of the representatives at the higher levels of the organization and cast doubt over the extent to which these elected representatives do really represent their constituency and the grass-roots organizations. This loss of legitimacy and representativity affects in turn the ability of the umbrella organization to represent all its constituencies. This ability is further reduced by the composition of the umbrella organization's AGM that guarantees a power balance between the two organizational lines and that privileges small organizations (in terms of membership) at the expense of the big ones. Low degrees of participation may also impede the well functioning of the AGMs and their capacity to hold the board representatives accountable provoking by this token oligarchic tendencies. Two mechanisms appear to counteract the dysfunctioning of the AGMs at the local level. On the one hand, the existence of election committees, proposing candidates to board positions and acting both as a censor of undemocratic behavior and as agent of renewal of the elected officials, limits the opportunities of oligarchic governance. On the other hand, the development of a network-based deliberative democracy beside the formal representative institutions through which the members have the opportunity to express their meaning ensures that the decisions made by the elected officials at the club level are rooted in their constituencies.

However, the development of a network-based deliberative democracy at the local level is not unproblematic. First, it entails a decoupling between participatory practices at the local levels and the hierarchic institutions of representative democracy at the other levels of the NOC. The result is a loss of representativity of the representative system and a loss of inputs from members and grass-roots organizations. Second, network-based democracy challenges the basic principles of liberal democracy (Sørensen & Torfing, 2005), since it undermines the boundaries that define a political community and do not guarantee the equality of formal democratic rights. New developments in democracy theory, the so-called post-liberal approaches to democracy, stresses however that the liberal principles do not guarantee that democracy functions well in practice. The outcome-oriented theory (Fung & Wright, 2003), for example, assesses democratic institutions on the basis of their ability to solve given problems (their outcome) and not on the basis of their basic principles.

Contrarily to Michels' (1949) prediction of an "iron law of oligarchy" affecting in the long run all types of voluntary organizations, we do not find evidences of oligarchic governance within the NOC. However, low grass-roots participation contributes to undermining the representative system on which the organization is based. If new forms of network-based deliberative democracy may partially solve the participation problem at the local level, it contributes to a decoupling between grass-roots and the NOC's hierarchical representative system. This fact raises a more general question, that of determining how hierarchical systems of representative democracy may adapt confronted with the development of a network society where hierarchy as organizational form is challenged.

References

- Allern, E.H., & Pedersen, 2007, "The impact of party organizational changes on democracy". *West European Politics*, 30:1, 68-92.
- Almond, G.A. and Verba, S., 1963, *The civic culture*. Boston: Little, Brown and Company.
- Andersen, S.S., 2007, "Kausalforklaringer is case-studier". *Tidskrift for Samfunnsforskning*, 48:4, 591-607.
- Arrow, K.J., 1951, *Social choice and individual values*. New Haven: Yale University Press.
- Bohman, J., Rehg, W. (Eds), 1997, *Deliberative democracy. Essays on reason and politics*. Cambridge M.A.: The MIT Press.
- Brady, H.E., Verba, S., Schlozman, K.L., 1995, "Beyond SES. A resource model of political participation", *American Political Science Review*, 89:2, 271-294.
- Cassinelli, C.W., 1953, "The law of oligarchy" *The American Political Science Review*, 47:3, 773-784.
- Castels, M. & Catterall, B., 2002, *Making of the Network Society*. London: Institute of Contemporary Art.
- Castells, M., (Ed), 2004, *The network society. A cross-cultural perspective*. Cheltenham: Edward Elgar.
- Cohen, J.L. and Arato, A., 1995, *Civil Society and Political Theory*. Cambridge: The MIT Press.
- Cohen, J. and Rogers, J., 1995, *Associations and democracy*, London: Verso.
- Cohen, J., 1997, Procedure and substance in deliberative democracy". In Bohman, J., Rehg, W. (Eds), 1997, *Deliberative democracy, Essays on reason and politics*. Cambridge M.A.: The MIT Press.
- Crick, B., 2002, *Democracy. A very short introduction*. Oxford: Oxford University Press.
- Cunningham, F., 2002, *Theories of democracy*. London: Routledge.
- Dahl, R.A., 1956, *A preface to democratic theory*. Chicago: University of Chicago Press.
- Dahl, R.A. (1989). *Democracy and its critics*. New Haven: Yale University Press.
- Dahl, R.A. (1982). *Dilemmas of Pluralist Democracy*. New Haven: Yale University Press.
- Downs, A., 1957, *An economic theory of democracy*. New York: Harper & Row.
- Dryzek, J.S., 2000, *Deliberative democracy and beyond*. Oxford: Oxford University Press.

- Elster, J., 1997, "The market and the forum" in Bohman, J., Rehg, W. (Eds), 1997, *Deliberative democracy, Essays on reason and politics*. Cambridge M.A.: The MIT Press.
- Elster, J. (Ed), 1998, *Deliberative democracy*. Cambridge: Cambridge University Press.
- Enjolras, B. 2004, *Idrett mellom statlig styring og selvbestemmelse*. Oslo: Institutt for samfunnsforskning, rapport 7:2004.
- Enjolras, B. & Seippel Ø., 2004, *Norske idrettslag 2000*. Oslo: Institutt for samfunnsforskning, rapport 4:2001.
- Etzioni-Halevy, E., 1993, *The elite connection*. Cambridge: Polity Press.
- Fung, A., & Wright, E.O., (eds.), 2003, *Deepning democracy*. London: Verso.
- Galston, W.A., 1999, "Diversity, toleration and deliberative democracy". In Maced, S. (Ed), *Deliberative politics*. Oxford: Oxford University Press.
- George, A.L., & Bennett, A., 2005, *Case studies and theory development in the social sciences*. Cambridge: MIT Press.
- Glendinning, C., Powell, M. & K. Rummery (eds.), 2002, *Partnerships, New Labour and the Governance of Welfare*. Bristol: The Policy Press.
- Gutmann, A. and Thompson, D. 1996, *Democracy and Disagreement*. Cambridge: The Belknap Press of Harvard University Press.
- Gutmann, A., Thompson, D., 2004, *Why deliberative democracy?* Princeton: Princeton University Press.
- Habermas, J., 1971, *Toward a rational society*. Boston: Beacon Press.
- Habermas, J., 1984, *The theory of communicative action*. Boston: Beacon Press.
- Habermas, J., 1990, "Morality and ethical life" in Habermas, *Moral consciousness and collective action*. Cambridge: MIT Press.
- Habermas, J., 1992, *The philosophical discourse of modernity*. Cambridge: MIT Press.
- Habermas, J., 1996, *Between facts and norms*. Cambridge: MIT Press.
- Held, D., 1996, *Models of Democracy*. Cambridge: Polity Press.
- Juris, J.S., 2004, "Networked social movements: global movements for global justice", in Castells, M., (Ed), *The network society. A cross-cultural perspective*. Cheltenham: Edward Elgar.
- Klausen, K.K., & Selle, P., 1996, "The third sector in Scandinavia". *Voluntas*, 7:2, 99-122.

- Kooiman, J. (ed.), 1993, *Modern Governance: New government society interactions*. London: Sage.
- Lorentzen, H., 1994, *Frivillighetens integrasjon*. Oslo: Universitetsforlaget.
- Lorentzen, H., 2004, *Fundament for fellesskap*. Sivilsamfunnet og individualismen. Oslo: Pax.
- Leach, D.K., 2005, "The iron law of what again? Conceptualizing oligarchy across organizational forms". *Sociological Theory*, 23:3, 312-337.
- Lipset, S.M. Trow, M.A. and Coleman, J.S., 1962, *Union Democracy*. New York: Anchor Books.
- Mansbridge, J.J. 1992, "A deliberative theory of interest representation". In Petracca, M.P. (Ed), *The politics of interests*. Boulder: Westview Press. 32-57.
- Manin, B., 1997, *The principles of representative government*. Cambridge: Cambridge University Press.
- Michels, R., 1949, 1962, *Political Parties*. New York: The Free Press.
- NIF (2006) Lov for Norges Idrettsforbund og Olympiske Komité.
- Olson, M., 1965, *The logic of collective action*. Cambridge: Harvard University Press.
- Panbianco, A., 1982, *Political Parties: organisation and power*. Cambridge: Cambridge University Press.
- Pitkin, H.F., 1967, *The concept of representation*. Berkeley: University of California Press.
- Podolny, J.M., Page, K.L., 1998, "Network forms of organization". *Annual Review of Sociology*, Vol. 24: 57-76.
- Przeworski, A., Stokes, S.C., Manin, B., 1999, *Democracy, accountability and representation*. Cambridge: Cambridge University Press.
- Rawls, J., 1971, *A Theory of Justice*. Cambridge: Harvard University Press.
- Rawls, J., 1993, *Political Liberalism*. New York: Columbia University Press.
- Riker, W.H., 1982, *Liberalism against populism*. Long Grove: Waveland Press.
- Rosenstone, S.J., Hansen, J.M., 1993, *Mobilization, participation and democracy in America*. New York : Macmillan.
- Salamon, L., (ed.), 2002, *The Tools of Government*. New York: Oxford University Press.

- Seippel, Ø. (2003) 'Norske idrettslag 2002. Kunnskap, ledelse og styring', Oslo: Institutt for samfunnsforskning.
- Selle, P. & Hestetun, P.A., 1990, *Fylkes- og krinsnivået i organisasjonsammenheng*. Bergen: Tano.
- Sivesind, K.H., Lorentzen, H., Selle, P., & D. Wollebæk, (2002), *The Voluntary Sector in Norway*. Oslo: Institutt for samfunnsforskning, rapport 2002:3.
St. meld 27 (1996/97) *Om statens forhold til frivillige organisasjoner*.
- Shapiro, I., 1999, "Enough of deliberation: Politics is about interest and power". In Maced, S. (Ed), *Deliberative politics*. Oxford: Oxford University Press.
- Skirstad, B. (2005) Women's Influence in 'Sport as Internal and External Stakeholders. In G. Doll-Tepper, G. Pfister, D.Scoretz, & C.Bilan. (Eds.), *Women and Leadership*. Congress proceedings (pp 131 -146). Cologne. Sport und Buch Strauss.
- St. meld 27 (1996/97) *Om statens forhold til frivillige organisasjoner*.
- Schumpeter, J. 1947, *Capitalism, Socialism and democracy*. London: Allen & Unwin.
- Sørensen, E., Torfing, J., 2005, "Network governance and post-liberal democracy".
Administrative Theory & Praxis, 27:2, 197-237.
- Tranvik, T. and Selle, P. (2003) *Farvel til folkestyret? Nasjonalstaten og de nye nettverkene*. Oslo: Gyldendal Norsk Forlag.
- Try, H., (1985), *Assosiasjonsånd og foreningsvekst i Norge. Forskningsoversyn og perspektiv* Alvheim & Eide.
- Verba, S., Schlozman, K.L., Brady, H.E., 1995, *Voice and equality. Civic voluntarism in American politics*. Cambridge M.A.: Harvard University Press.
- Warren, M.E., *Democracy and association*. Princeton: Princeton University Press.
- Wilson, J.Q. (1973). *Political Organisations*. New York: Basic Books.
- Wollebæk, D., Selle, P., & H. Lorentzen, (2000), *Frivillig innsats*. Bergen: Fagbokforlaget.
- Young, I.M., 1999, "Justice, inclusion and deliberative democracy". In Maced, S. (Ed), *Deliberative politics*. Oxford: Oxford University Press.
- Young, I.M., 2000, *Inclusion and democracy*, Oxford: Oxford University Press.
- Østerud, Ø, Engelstad,F., & P. Selle, 2003, *Makten og demokratiet*. Oslo: Gyldendal.