

# **Social Capital: The Measurement Tool**

**Paul Bullen and Jenny Onyx**

Paul Bullen:

Management Alternatives Pty Ltd

PO Box 181, Coogee, NSW, 2034

Australia

Phone: (02) 9665 7737

Fax: (02) 9315 7542

web page: [www.mapl.com.au](http://www.mapl.com.au)

email: [paul.bullen@mapl.com.au](mailto:paul.bullen@mapl.com.au)

Jenny Onyx, Professor, University of Technology, Sydney

Professor , School of Management

Director, CACOM (Centre for Australian Community Organisations and Management)

P.O. Box 123 Broadway, NSW 2007

Phone: +61 02 9514 3633,

Email: [Jenny.onyx@uts.edu.au](mailto:Jenny.onyx@uts.edu.au)

## Abstract

This paper reports a meta-analysis of the Onyx and Bullen social capital scale. A confirmatory factor analysis was found to be extremely robust and enabled a comparison between communities, not only on the overall social capital scores, but also on the primary factors. Secondly, the paper reports the results of an exploratory causal path analysis. By using structural equation modelling, we were able to explore a number of plausible causal paths between the social capital factors. While several solutions are plausible, one solution is strongest. This model suggests that, of all the factors, **Social Agency** and **Trust** are the strongest causal factors. The factor **Neighbourhood Connections** is an important mediating factor. **Community Participation** is an outcome factor in the forward model. However in the reverse model, Community Participation links quite strongly both to Family/Friendship and to Neighbourhood connections, as well as to trust, suggesting that social capital is iterative in its production.

## Social Capital: The Measurement Tool

This paper reports a meta-analysis of the Onyx and Bullen scale that was originally published to measure social capital. Since the scale was published in 2000, it has been used in a variety of contexts. Based on the combined data from twelve samples totalling over 6,000, the original factor analysis is repeated, and found to be extremely robust. On the basis of this confirmatory analysis, a comparison between communities is made, not only on the overall social capital scores, but also on the primary factors. Secondly, the paper reports the results of an exploratory causal path analysis of the total data from all samples, using SEPATH. This paper has explored new ground in the measurement of social capital. By using structural equation modelling, we were able to explore a number of plausible causal paths between the social capital factors. We found that a number of different causal paths do “work”. What that means is that social capital can be developed in quite different ways for different people in different communities. However we also found that one path is very plausible, and better than many other models that were explored, and that the reverse of that model is also plausible. Taking both models together we take the findings to mean that social capital is indeed, iterative, that is that the more social capital is developed, the more can be developed. In terms of the model, while several factors impact on community participation, community participation in turn impacts on those other factors.

The dominant, most plausible forward model suggests that, of all the factors, **Social Agency** and **Trust** are the most important causal factors. They are the factors most likely to lead to other good outcomes, notably Neighbourhood Connections, Value of Life and Tolerance of Diversity. The factor **Neighbourhood Connections** is an important mediating factor. Strong levels of Neighbourhood Connections are most likely to lead to strong family/friendship networks and to Community Participation. **Community Participation** is an outcome factor in the forward model. That is other factors lead to it, not the other way round. However note that in the reverse model, Community Participation links quite strongly both to Family/Friendship and to Neighbourhood connections, as well as to trust. This again is suggestive of a virtuous cycle in the production of social capital.

The concept of social capital entered the spotlight in the mid 90's from the work of Robert Putnam and colleagues. His definition, which still forms the basis of much work was "those features of social organisation, such as trust, norms and networks that can improve the efficiency of society by facilitating coordinated actions" (Putnam, 1993). Many claims were made for social capital. Putnam's original work in Italy suggested that high levels of social capital were associated with stable governance and economic prosperity. Other researchers have claimed that social capital is associated with good health, good educational outcomes, lower crime, a stronger community.

A major problem with the concept of social capital has been finding adequate measures of it. Few macro statistics have been available, none relating explicitly to social capital. Several surrogate measures have been used as indicators, such as rates of volunteering and the social values question "Do you believe that most people can be trusted?"

Apart from the measurement of social capital, there is a growing consensus that it is a complex multilayered concept, with several components. That raises the further question of which elements of social capital are core to the concept, and which are peripheral. Certainly there is consensus in the literature that social capital stands for the ability of actors (both group and individual) to secure benefits by virtue of membership in social networks or other social structures (Portes 1998). But which networks, and how do they generate social capital?

One point of discussion concerns the centrality of trust. For some it is critical, (Fukuyama 1995; Misztal 1996; Putnam 1993) for others simply a fortunate side effect (Portes 1998; Woolcock 2001; Schuller 2001). Other scholars have emphasized different core elements of social capital, elements such as reciprocity (Putnam 1993) and social agency (Leonard and Onyx, 2004). Agency refers to the capacity to take the initiative, to be proactive.

In this context the Onyx and Bullen scale of social capital was developed (1997, 2000). Since that original scale was published, it has subsequently been adopted in a range of settings, both to measure social capital at the community level and to measure different demographic groups such as volunteers, or family support clients.

This paper now reports a meta-analysis of the Onyx and Bullen scale. The original factor analysis is repeated, and on the basis of this confirmatory analysis, a comparison between communities is made, not only on the overall social capital scores, but also on the primary factors.

Secondly, the paper reports the results of an exploratory causal path analysis of the total data from all samples, using SEPATH. A causal analysis examines the links between factors, and attempts to identify the most plausible causal chain between them.

### **The original analysis**

The final questionnaire of the original scale developed in 1997 included several items to tap each of the dimensions identified in the theoretical literature such as trust, networks, reciprocity, as well as others that emerged in preliminary workshop discussions: those relating to attitudes (value of self), openness to diversity, relations within the workplace, attitudes to government, and demographic information. Each of 68 social capital items was provided with a four point likert response scale ranging from 1 (No, not much or No, not at all) to 4 (Yes, definitely or yes, frequently).

The five communities chosen for the initial sample included two in rural areas of NSW, two in outer metropolitan areas of Sydney Australia, and one inner city area. Each participating centre was given detailed instructions and assistance in achieving a local sample that was a broad cross section of adults in the community. Actual methods varied in each area, but in all cases, a proportion of the sample was obtained from a doorknocking procedure modelled on the census collection procedure. Additional procedures used included setting up stalls in public places like shopping centres and approaching local community centres like child care centres, schools and local workplaces

The sample comprised 1,211 citizens between the ages of 18 and 65 living in rural and urban areas of NSW. While the sample cannot be considered a representative sample in the strict sense of the term, it taps a broad cross section of adults living and working in NSW in 1997.

The questionnaires were analysed using STATISTICA. Factor analysis and inter-item reliability analysis were used to identify the elements of social capital and also to determine which questions were related to social capital and which ones were not. A Hierarchical Factor Analysis was carried out using the STATISTICA package. By this means a set of oblique factors may be identified and correlations between them computed. Then “that correlation matrix of oblique factors is further factor-analysed to yield a set of orthogonal factors that divide the variability in the items into that due to shared or common variance (secondary factors) and unique variance due to the clusters of similar variables (items) in the analysis (primary factors)” (Statistica for windows, 1994, vol 3, p.3195). In other words, the analysis permitted the identification of any general factor that might exist, as well as a set of specific factors that might identify the separate components of social capital.

After considerable exploration of the data, the solution finally adopted used 36 of the original 68 items. The final solution identified eight specific independent factors and one clear General (secondary) Factor. The eight factors together accounted for 49.3% of the total variance. The obtained factor structure remained stable across each of the five separate area subsamples of the total sample, as well as across several subsequent data sets (not included in the present analysis).

The meaning of each factor can be inferred from the item content. The identified factors were:

**Factor A:** “Participation in the Local Community” refers to participation in formal community structures (e.g “ are you an active member of a local organisation or club?”).

**Factor B:** “Social Agency, or Proactivity in a Social Context” refers to a sense of personal and collective efficacy, or personal agency within a social context. Agency refers to the capacity of the individual to plan and initiate action (e.g “if you need information to make a life decision, do you know where to find that information?”).

**Factor C:** “Feelings of Trust and Safety” is defined by items such as “do you agree that most people can be trusted”.

**Factor D:** “Neighbourhood Connections” concerns the more informal interaction within the local area (e.g “have you visited a neighbour in the past week?”).

**Factor E:** “Family and Friends Connections” is defined by items such as “in the past week how many phone conversations have you had with friends?”

**Factor F:** “Tolerance of Diversity” is defined by items such as “do you think that multiculturalism makes life in your area better?”

**Factor G:** “Value of Life” is defined by items such as “ do you feel valued by society?”

**Factor H:** “Work connections” (for people in paid employment) is defined by items such as “are your workmates also your friends?”

The Hierarchical Factor Analysis produced only one clear General (second order) factor. The Cronbach alpha for these 36 items was .84;

### **Further Comparative Analysis**

Since the original scale was first published, it has subsequently been adopted in a range of settings, both to measure social capital at the community level and to measure different demographic groups (such as volunteers, community workers, family support clients). At the community level the scale has been used in NSW (six communities), Western Australia, Queensland, New Zealand, and Midwest U.S. (O’Brien, Burdsal, and Molgaard, 2004). The combined sample used in the meta analysis reported here, is based on 6,249 individuals..

The study Measuring Social Capital in Five Communities in NSW identified 7 factors (A to G above) measured by 31 questions. A factor analysis of the data from the nine studies gathered here, representing nine communities and four demographic groups, was undertaken. It replicated the factor structure in the original study. For 28 out of the 31 questions the largest factor loading was on the same factor as the original study. For three questions the largest loading was on a different factor (significant loadings were also on the original factor).

A hierarchical factor analysis was also undertaken. All 31 questions had loadings of between .28 to .48 on the second order factor (general social capital) - confirming the findings in the original study of the existence of the second order factor.

A confirmatory factor analysis was undertaken using structural equation modelling.

See the statistical notes for details. It also confirmed the factor structure. We can conclude that the factor structure is extremely robust across a range of contexts.

The factor structure is extremely robust. This allows comparison between communities. Figure 1 below illustrates the variation in the general social capital factor over all communities and four demographic groups.

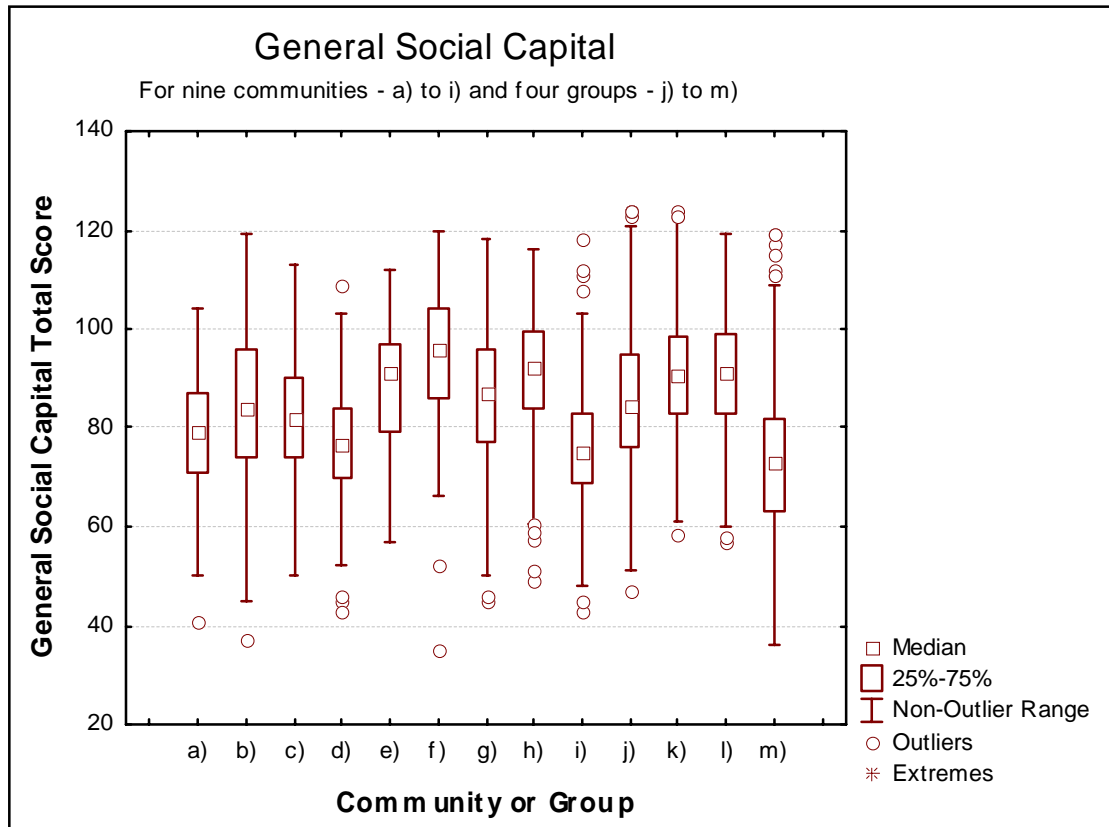

Figure One

This variation occurs not only on the overall social capital scores, but also on the primary factors. It is apparent that each community measured has a distinct profile, so that a community will be strong on one factor but much weaker on some other factor that is a second community's strength.

Table 1: Social Capital Scores across Nine Communities.

Location Factor	Pyrmont	Narellan	Green-acre	Deniliquin	West Wyalong	Broken Hill	Melany	South Lake	US
A. Community Connections	11.7	12.6	11.0	14.3	15.5	15.9	19.0	9.1	14.1
B. Proactivity/Social Agency	15.8	15.8	14.9	14.3	15.0	15.2	15.8	15.2	16.9
C. Trust and Safety	12.2	13.0	10.6	13.0	16.1	13.7	16.1	12.4	14.9
D. Neighbourhood Connections	11.8	14.1	13.6	15.0	15.2	14.4	15.2	13.3	14.7
D. Family/Friends	9.7	9.4	9.0	9.4	9.1	9.0	9.2	7.3	9.1
F. Tolerance of Diversity	6.4	5.4	5.3	5.8	4.8	5.7	6.8	6.1	6.7
G. Value of Life	5.5	5.5	5.3	5.8	6.2	5.9	5.8	5.6	6.3
General SC	79.7	82.6	76.7	84.0	88.2	80.0	94.7	75.8	90.9
No of respondents	247	233	256	266	209	635	137	976	379

A few examples will illustrate the different patterns obtained. The four rural samples are those shaded on the right. In general, the rural samples demonstrated higher levels of social capital than did the urban samples, with the exception of Broken Hill. By far the highest social capital is evidenced in Maleny, a small rural town in the hinterland of coastal Queensland. This community is remarkable not only for its strong community connections, but also for its strong tolerance of diversity, a quality not normally found in rural samples. Broken Hill, a mining town in outback NSW has high levels of community participation but relatively low levels of trust and neighbourhood connections. However the lowest level of trust and safety was experienced in Greenacre, a largely poor, public housing area of outer Sydney. An area that also demonstrates lowest overall social capital, and lowest levels of community participation.

### The Causal Path Analysis

We wished to explore the possibility that there are causal connections between the factors and if so what these causal connections would be. From the literature a variety of plausible causal connections were identified. For example, two possible causal paths could be:

- Family and friends --> Neighbourhood connections --> Trust and safety -->

## Community connections

- Trust and safety & Proactivity --> Community connections --> Neighbourhood connections --> Tolerance of diversity.

Given there are 7 factors and each factor could be connected to multiple other factors there are a very large number of possible causal models. There are also multiple theoretical perspectives also leading to multiple possible causal models. We were therefore interested, not in confirming a particular theoretical position, but rather in exploring which causal models are most plausible. This paper explores causal connections between social capital factors using structural equation modelling.

Structural equation modelling in its most general form is a combination of path analysis and factor analysis. As suggested by Klem (2000), “In path analysis, the concern is with the predictive ordering of *measured variables*. For example  $X \rightarrow Y \rightarrow Z$  is a path analysis model in which X, Y and Z are measured variables and the arrows represent the hypothesised causal effects. In a full structural equation model, the concern is the predictive ordering of *factors*. A structural equation model in which the Fs are factors is  $F1 \rightarrow F2 \rightarrow F3$ , and just as in path analysis, the arrows represent hypothesized causal effects.”

We started the analysis by exploring models suggested by different theoretical perspectives. For example elements of paths that were explored included:

- Family and friends --> Neighbourhood connections --> Community connections
- Trust and safety & Proactivity --> Community connections --> Neighbourhood connections --> Family and friends
- Family and friends --> Neighbourhood connections --> Trust and safety & Tolerance of diversity --> Community connections
- Trust and safety & Proactivity --> Community connections --> Neighbourhood connections --> Tolerance of diversity.

In exploring over 20 different models (each including all 7 factors) being suggested by theory and/or their opposites (ie, models going in the opposite causal direction being suggested by theory) we found that many of the proposed models worked ‘moderately well enough’ to ‘not so well’. None of them worked ‘very well’.

Given there are 7 factors, there are 42 different paths (A-->B, A-->C, etc). These 42 different paths can be structured in many different ways (eg, A-->B or A-->B & C, or A-->B&C&D, etc). We did notice in these models however that the path coefficients varied greatly from one path to another (eg the path coefficient A-->B was relatively high, and the path coefficient A --> F was relatively low).

Because there were so many possible models that could be theoretically justified we started asking the question in a different way: What would be the distribution of the path coefficients in a large number of randomly generated structural models? If some paths were more likely to be cause and effect linkages than others, *on average* those paths would have higher path coefficients than paths that did not have cause and effect linkages.

To explore this idea we generated 138 path models and for 136 of them found the means and standard deviations of the path coefficients for each of the 42 possible paths (A-->B, A-->C, etc).

The means and standard deviations of the path coefficients were then used to develop two well fitting path models (see appendix for further details of this process). We conclude that there is no one definitive causal path, but that a very plausible causal path for the development of social capital is the 'Forward Model' presented in figure three below and that the reverse of this path, the Reverse Model, is also plausible, but not quite as good. The forward path model was a generally better fit than any of the randomly generated models and any of the initial theory generated models.

In reviewing the randomly generated models the better fitting models tended to be the more complex models. The fit of the two models here can be improved by adding three paths to the forward model (C-->B, B-->A and E-->G) and four paths to the Reverse model (F-->G, G-->D, G-->E and A-->B). The increased complexity requires larger sample sizes and so in the analysis here comparing communities the less complex model was used.

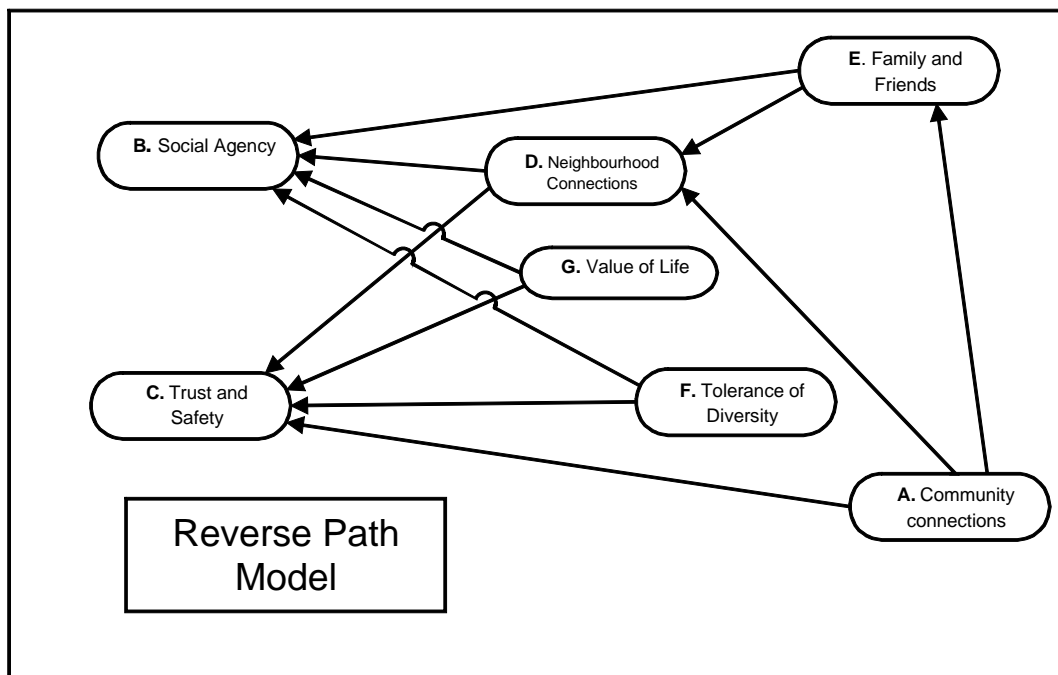
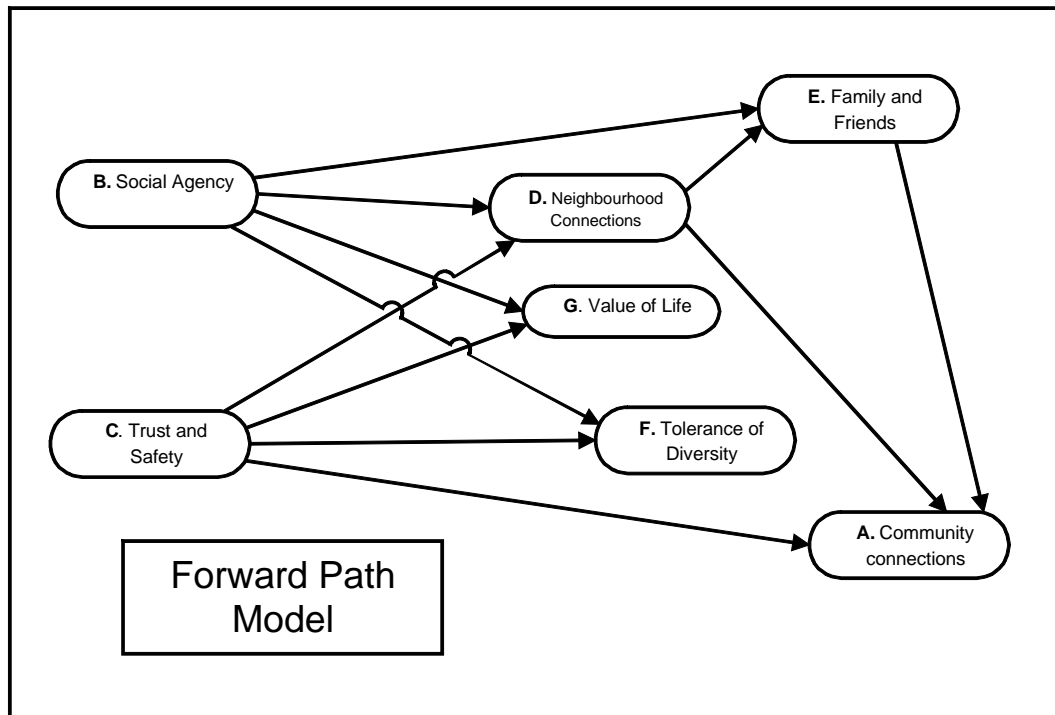

**Figure two and three**

An elaborated diagram of the forward and reverse path models is presented in figures 4 and 5 below. These models are based on the combined data from all nine studies.

The models include:

- The causal paths for the factors
- The path coefficients for these causal paths
- For each factor the loadings on the questions
- For each question the unexplained variance.

- For each dependent factor the unexplained variance.

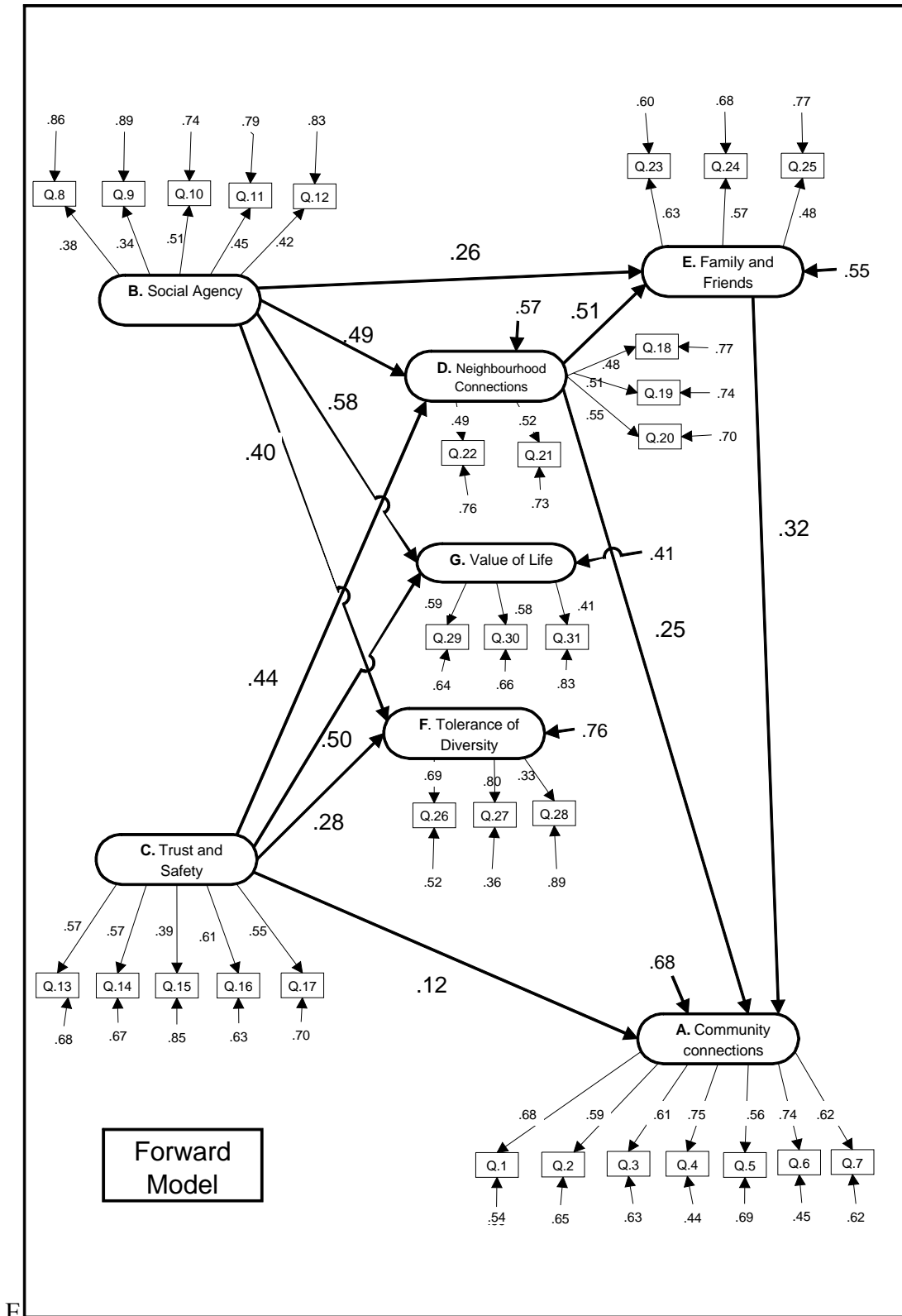

Figure 4



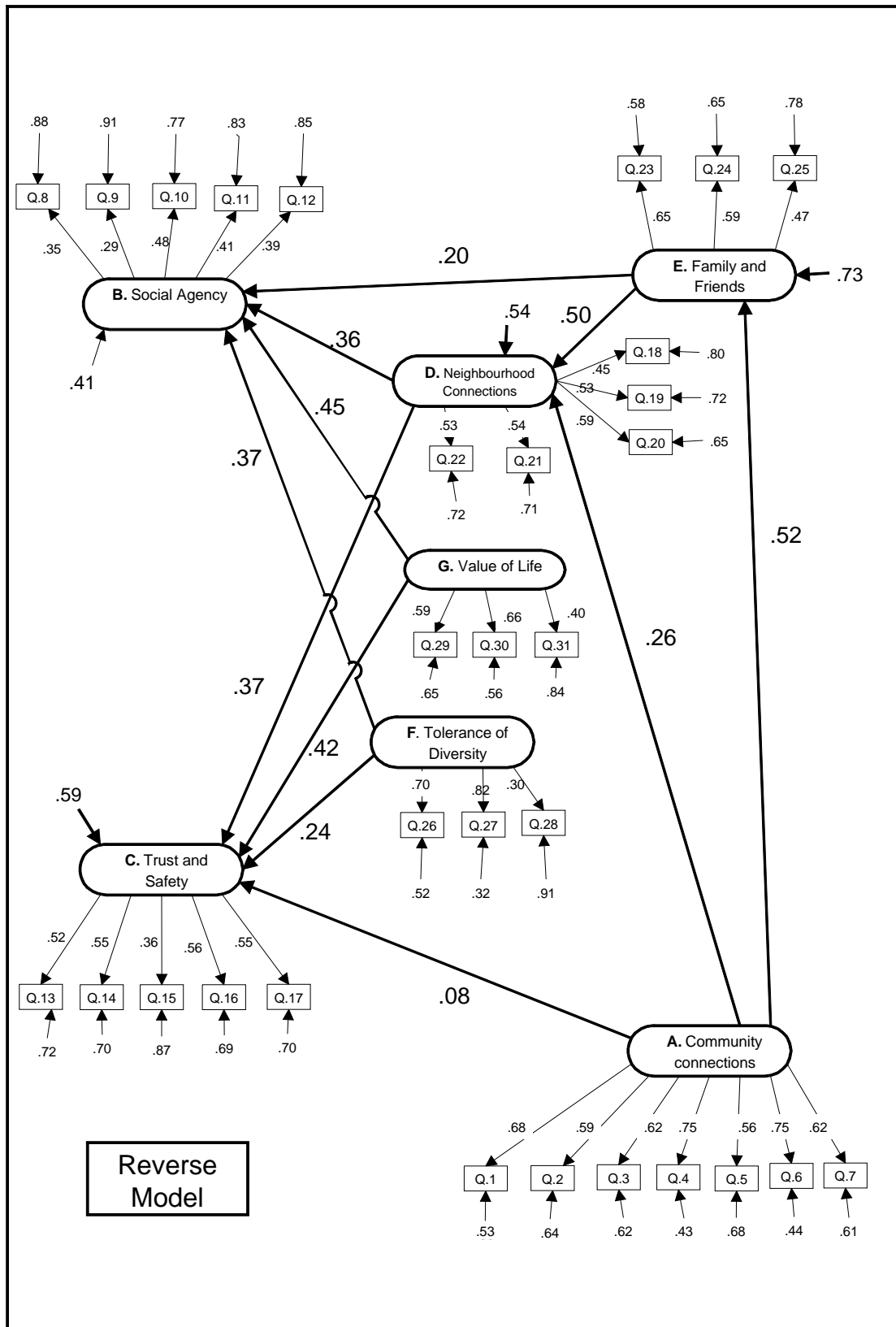

Figure 5

### **Comparing communities and groups**

The Forward and Reverse structural equation models above can be used to explore the question: Are the causal connections between social capital factors the same across communities, or different from one community to another? As we have demonstrated, Communities vary greatly in the levels and mix of social capital. These differences tell us about the amount of social capital, not the causal connections between factors. However we are able to explore the causal connections between factors by using the Forward and Reverse structural models that have been identified above to see if there are significant differences between the path coefficients in each community and/or group.

The path coefficients are explored for three communities. The three communities that are included are the three with the biggest sample sizes.

The analysis was undertaken in such a way that these three communities (and two groups) were combined into one analysis which was used to generate a measurement model within which each of the three communities (and two groups) could have path coefficients unique to the community or group respectively.

The following two graphs show the path coefficients for each of the three communities for the Forward and Reverse path models.

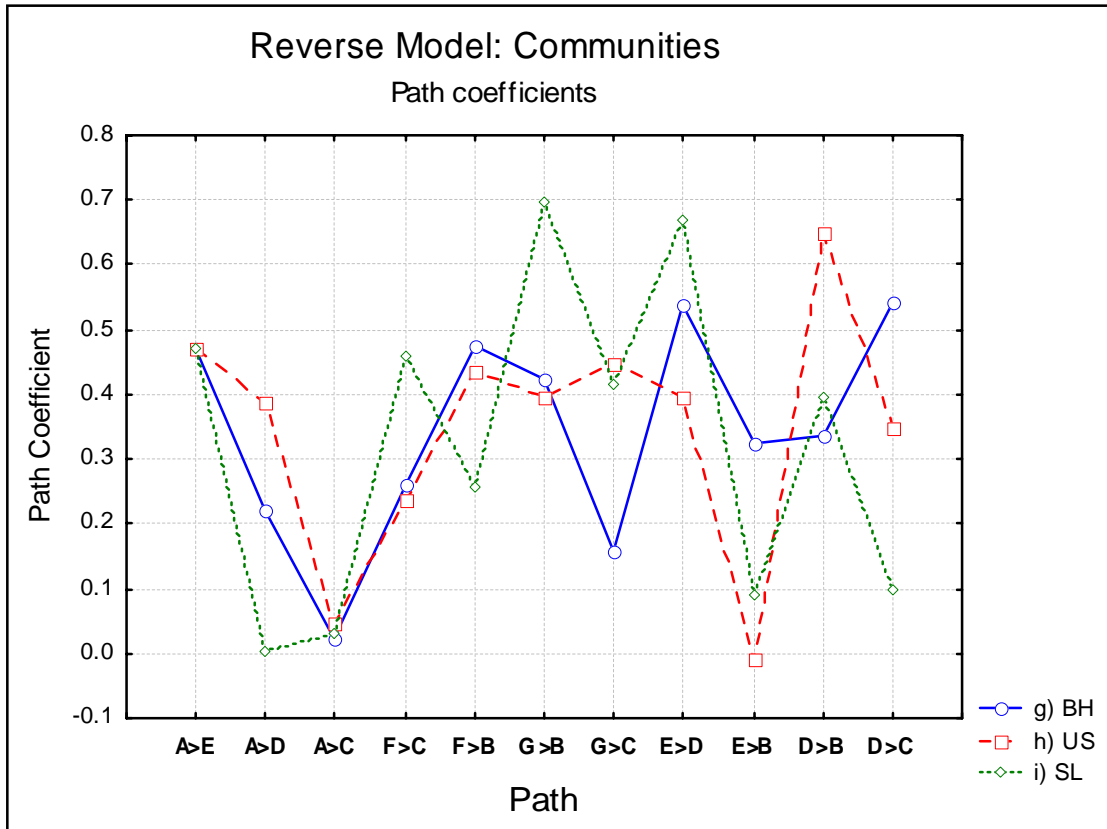
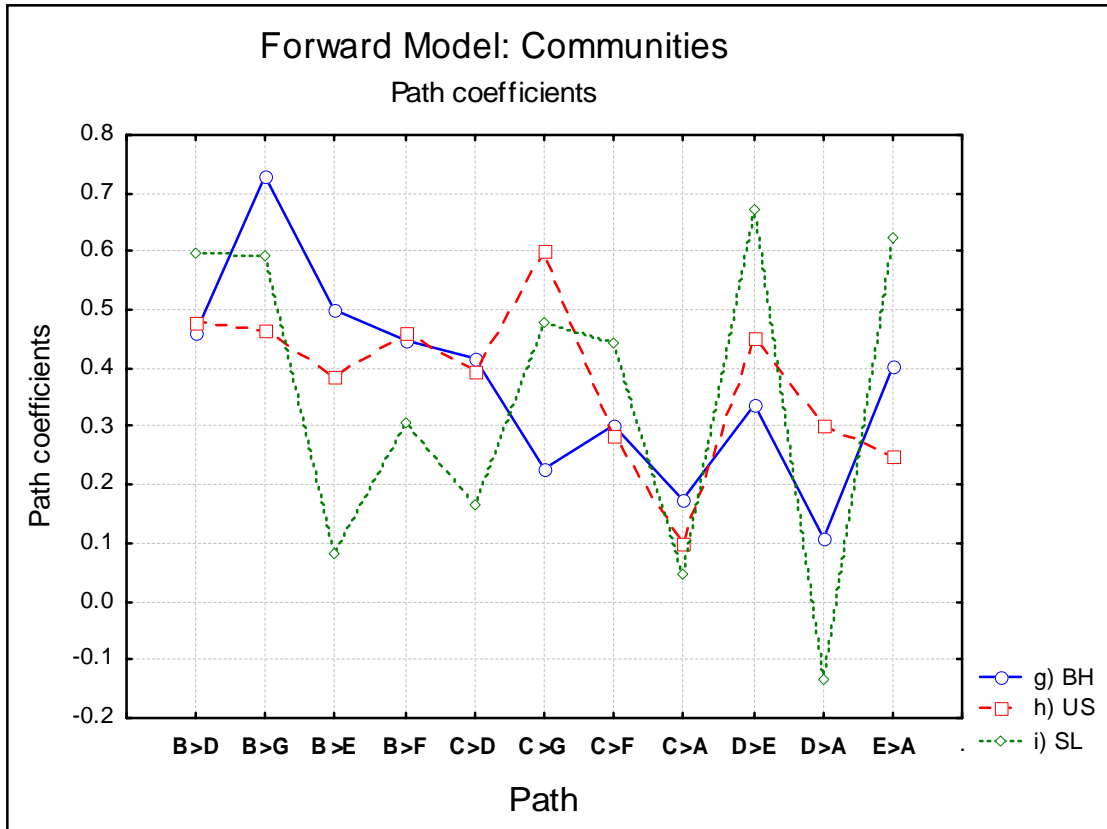

**Figures six and seven**

There are significant differences between communities and groups in the Forward model. For example:

- Broken Hill has a comparatively high B-->G path coefficient and comparatively low C-->G path coefficient. That is Social Agency is more likely to lead to a high Value of Life in Broken Hill but Trust is not.
- South Lake has comparatively very low B-->E, C-->D, and D-->A path coefficients. That is in South Lake, social agency is *not* likely to lead to good family/ friendship networks, trust is *not* likely to lead to good neighbourhood connections, and Neighbourhood Connections are *Not* likely to lead to Community Participation
- The US Mid West has a comparatively high C-->G path coefficient. That is, in this Midwest American community, Trust is more likely to lead to high Value of Life.

## **Discussion**

We have established that the factor structure of this social capital scale is very stable across communities and groups. We have also established that the scale can identify significant and meaningful differences in factor structure between communities and between different demographic groups.

This paper has explored new ground in the measurement of social capital. By using structural equation modelling, we were able to explore a number of plausible causal paths between the social capital factors. In simple language, we want to know which social capital factors have a causal influence on other factors. There has been much broad theoretical discussion in the literature but no empirical data on the most likely casual path. Rather than trying to confirm a particular theoretical path, this paper has initiated a broad exploratory analysis. We found that a number of different causal paths do “work”. What that means is that social capital can be developed in quite different ways for different people in different communities. However we also found that one path is very plausible, and better than many other models that were explored, and that the reverse of that model is also plausible. Taking both models together we take the findings to mean that social capital is indeed, iterative, that is that the more social capital is developed, the more can be developed. In terms of the model, while several factors impact on community participation, community participation in turn

impacts on those other factors.

The dominant, most plausible forward model suggests that, of all the factors, **Social Agency** and **Trust** are the most important causal factors. They are the factors most likely to lead to other good outcomes, notably Neighbourhood Connections, Value of Life and Tolerance of Diversity. The factor **Neighbourhood Connections** is an important mediating factor. Strong levels of Neighbourhood Connections are most likely to lead to strong family/friendship networks and to Community Participation. **Community Participation** is an outcome factor in the forward model. That is other factors lead to it, not the other way round. However note that in the reverse model, Community Participation links quite strongly both to Family/Friendship and to Neighbourhood connections, as well as to trust. This again is suggestive of a virtuous cycle in the production of social capital.

Again, we note that communities vary in terms of the strength of the various paths within the structural equation modelling. These community differences suggest that not only do communities differ in their social capital profile, but the mechanisms by which social capital is developed also vary from one community to another. A great deal more work needs to be done to explicate these differences and what they may mean. Certainly there are significant implications for community building strategies. What works, in social capital terms, in one community may not work in another.

In conclusion, we have opened what is likely to lead to a significant new line of research in social capital research. We have answered our initial questions. First, the structure of social capital is indeed remarkably stable across communities and groups and thus allows an analysis of different social capital profiles in different communities. Second, it is possible to identify plausible causal paths to the development of social capital. Again the strength of these paths is likely to differ between different communities. However, of course the data on which this analysis is based, is correlational in nature. A great deal of further empirical work needs to be done concerning the nature of these causal paths, using a variety of time series data. We also need to know a great deal more about the implications of these causal paths, and their differences between communities. As usual, we have answered some

questions, but raised a great many more.

## References

- Fukuyama, F. 1995. *Trust: the Social Virtues and the Creation of Prosperity*. London: Penguin
- Klem, L. (2000). Structural Equation Modeling in Reading and Understanding More Multivariate Statistics edited by L.G. Grimm and P.R. Yarnold, American Psychological Association,
- Leonard and Onyx, in press. *Spinning Straw into Gold: Social capital in practice*. London, Janus
- Miztral, B. 1996 *Trust in Modern Societies*. Polity Press, Cambridge MA
- O'Brien, M., Burdsal, C., and Molgaard, C. (2004) Further development of an Australian-based measure of social capital in a U.S. sample. *Social Science and Medicine*, 59, 1207-1217.
- Onyx, J. and P. Bullen. 2000. The different faces of social capital in NSW Australia. In P. Dekker and E. Uslander (eds.), *Social Capital and Participation in Everyday Life*. London: Routledge
- Onyx, J. and P. Bullen. 2000. Measuring social capital in five communities. In *Journal of Applied Behavioural Science* 36(1): 23-42
- Portes, A. 1998. Social capital: its origins and applications in modern sociology, *Annual Review of Sociology*, Vol. 24, No. 1, pp. 1-24.
- Putman, R. 2000. *Bowling Alone*. New York: Simon & Schuster
- Putman, R., R. Leonardi and R. Nanetti. 1993. *Making Democracy Work: Civic Traditions in Modern Italy*. Princeton, New Jersey: Princeton University Press
- Schuller, T. (2001) The complimentary roles of human and social capital, *Canadian Journal of Policy Research*, Vol. 2, No. 1, pp. 18-24
- Woolcock, M. 2001. The place of social capital in understanding social and economic outcomes, *Canadian Journal of Policy Research*, Vol. 2, No. 1, pp. 11-17

## Appendix

### Randomly generating 138 SEM models

To generate models for the exploratory process we set some parameters:

Each model would be a three step model (ie have a beginning, a middle and an end).

Each model would include all seven factors.

Each factor would connect to all the factors in the next step of the model.

There are fifteen different structures that meet the requirement of being a three step model and including 7 factors. Here are three examples of these 15 structures:

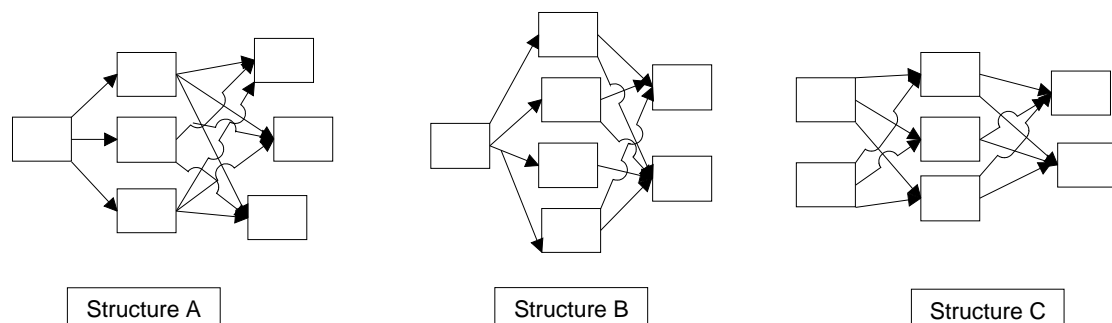

For each of these fifteen structures the seven factors were randomly allocated within the structure. For example in structure A the first model included the factors C; E,G,B; F,B,A in the three steps. This process was repeated 7 times for each structure. In structure A the second model included the factors A; D,B,F; C,G,B.

This generated 105 structural equation models (7 for each of 15 structures).

These 105 models were reviewed and the structure what was producing the best fitting models (Structure C above) was used to randomly generate a further 33 models giving a total of 138 models.

All the models where the RMSEA was .1 or less were taken to be a good enough fit for further analysis. Two models failed this test.

There are 42 possible paths (A-->B, A-->C etc). The paths fall into two groups of 21. The second 21 paths are the reverse of the first 21 paths (A-->B and B-->A).

The 1370 path coefficients in these 136 models were grouped into their respective paths (A-->B, A-->C etc) and the mean and standard deviation calculated for each path.

The following chart shows the means for the path coefficients. There are 21 possible paths: A-->B, A-->C, A-->D etc. There are a further 21 reversed paths B-->A, C-->A, D-->A, etc

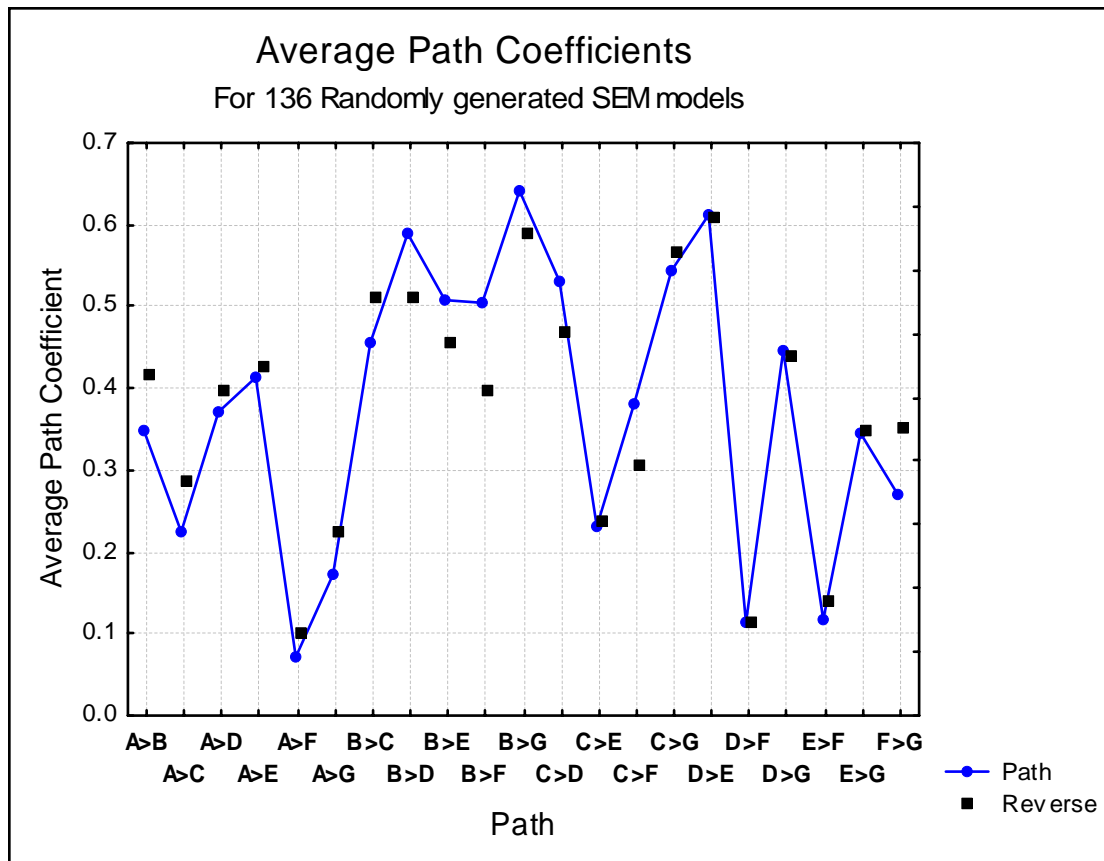

This data suggested:

- Some paths are more likely to work in one direction than the other. For example, on average in the 136 models the path B-->D has higher path loadings (0.6) than the path D-->B (0.5).
- Some paths have very low path loadings in both directions, eg, A-->F (F-->A), D-->F, (F-->D )
- Some paths have moderate to high loadings in both directions, eg, A-->E, E-->A.

In the light of these distributions of path coefficients a structural equation model was developed that:

- Included the paths that were moderate to high and had higher loadings their reverse, eg. B-->D, B-->F
- Included the paths that were moderate to high loadings
- Excluded all paths with negligible or very low loadings, eg, A-->F, F-->A, C-->E, E-->C, E-->C, D-->F, F-->D
- Included moderate loadings.

In developing the model there were some constraints from the nature of structural equation modelling:

Paths could not be circular. There must be a beginning and an end.

The same factors could not be in two different places in a causal sequence.

In the real world these two assumptions are probably false and highlight the oversimplification taking place in this analysis.

### **Sample sizes N1 and N2**

There are 6249 cases in the study (N1).

There are 4618 cases in which there is no missing data on the social capital questions (N2). N2 is used in all structural equation and factor analyses.

### **Samples S1 and S2**

The 4618 cases in N2 were randomly divided into two samples S1 and S2.

Most of the structural equation modelling analyses were undertaken separately with these two samples - to see if the results in the first sample could be replicated with the second sample.

Where results could not be replicated in the second sample they have not been relied on. For example Narellan, Greenacre and the other communities with smaller sample sizes were not able to replicate similar path coefficients for both S1 and S2 and so were not included in the analysis of differences between communities.

### **Factors and questions**

The questions were grouped into factors on the basis of the original factors and question groupings. In addition the two 'other' questions which are not usually added together in the individual factor scores were included in the F and G factors (as they loaded on these questions (and others)).

### **Statistical software**

STATISTICA 7 used for all statistical analysis.

### **Structural equation solution**

The structural equation models have been developed using a standardised solution via constrained estimation. this approach produces a solution where all latent and manifest variables variances of 1. This method, described by Browne and DuToit (1987), and Mels (1989), is a constrained Fisher Scoring algorithm. This is not the same as the problematic "standardised" solutions generated in LISREL VI and CALIS.

## Model Fit

The Confirmatory Factor Analysis and the Forward and Reverse Models, are based on the combined data from all nine studies (nine communities and four groups). The fit statistics are:

	Forward	Reverse	CFA
Steiger-Lind RMSEA Index	.057	.060	.089
RMS Standardized Residual	.068	.089	.147
Adjusted Population Gamma Index	.906	.897	.801
Joreskog AGFI	.900	.891	.797
Independence Model Chi-Square	32979	32979	32979
Independence Model df	465	465	465
Bentler-Bonett Non-Normed Fit Index	.806	.803	.639
Bentler Comparative fit Index	.823	.803	.663

The Forward Model is the best fit.

The Reverse model is a good fit, but not as good as the Forward model.

The Confirmatory Factory Analysis is a good enough fit given the nature of social capital and the measurement tool.

## More complex models

In reviewing the randomly generated models the better fitting models tended to be the more complex models. The fit of the Forward Model and Reverse Model can both be improved by adding three paths to the Forward Model (C-->B, B-->A and E-->G) and four paths to the Reverse Model (F-->G, G-->D, G-->E and A-->B). The increased complexity requires larger sample sizes and so in the analysis here comparing communities the less complex model was used.

## Samples

The nine studies include the following samples

<i>Communities</i>	<b>N1</b>	<b>N2</b>
a) Ultimo/Pymont, Inner City Sydney, NSW	247	199
b) Deniliquin, Rural, NSW	266	230
c) Narellan, Outer Sydney, NSW	233	183
d) Green Acre, Wester Sydney, NSW	256	186
e) West Wyalong, Rural NSW	209	192
f) Melany, Rural QLD	137	113
g) Broken Hill, Western NSW	635	494
h) US Mid West	496	379
i) South Lake, Urban, WA	976	586
<i>Neighbourhood Centres (NC) and Family Support services</i>		
j) NC Group participants (NSW)	944	649
k) NC volunteers (NSW)	378	246
l) NC staff (NSW)	796	644
m) Family support clients (NSW)	676	517

The Ultimo/Pymont, Deniliquin, Narellan, Green Acre and West Wyalong data is from the study "Measuring Social Capital in Five Communities in NSW" (Jenny Onyx and Paul Bullen)

The South Lake Ottey and Family and Neighbourhood Centre provided the South Lake data from the study "The Community of South Lake Measuring Social Capital and Community Pride" 2002 (Margaret Auld and Margaret O'Neil)

Megan O'Brien provided the data from the US Mid West (a community of approximately 350,000 residents) from the study "Further development of an Australia-based measure of social capital in a US sample" 2004

The Neighbourhood and Community Centre data is from the study "Social Capital and Family Support Services and Neighbourhood and community centres in NSW" 1999, 2005 (Paul Bullen and Jenny Onyx).